

泰威

TAWI

Smart lifting

瑞典总部
TAWI AB
地址: Box 102 05
Kungsbacka434 23
电话: +46 300 -185 00
邮箱: info@tawi.com

中国
TAWI CHINA
泰威(苏州)自动化有限公司
地址: 江苏省太仓市太仓港经济技术开发区
欧美工业园3号厂房
电话: 4008-066-012
邮箱: salescn@tawi.com

丹麦
TAWI DANMARK
地址: A/S Arresøvej
7 DK-8240 Risskov
电话: +45 86 17 22 66
邮箱: mail@tawidanmark.dk

美国
TAWI USA
地址: 380 Internationale Drive
Bolingbrook, IL 60527
电话: +1 630-655-2905
邮箱: sales@tawi.us

德国
TAWI GmbH
地址: August-Thyssen-Str. 1
D-41564 Kaarst
电话: +49 211 20542740
邮箱: info@tawi.de

法国
TAWI Levalair
地址: 18 rue Denis Papin
95250 Beauchamp
电话: +33 1 39 95 65 00
邮箱: info@levalair.fr

英国
TAWI UK Ltd
地址: Unit G, Pentagon Park,
io Centre, Lodge Farm Ind Est
Northampton, NN57UW
电话: +44 1604 591120
邮箱: sales.uk@tawi.com

加拿大
TAWI Canada Inc.
地址: 3A-15 West Pearce Street
Richmond Hill ON L4B1H67
电话: +1 905 889 1633
邮箱: info@tawi.ca

荷兰
TAWI BV
地址: Postbus 6092
5700 ET Helmond
Houtse Parallelweg 34-35
5706 AB HELMOND
电话: +31 492-523705
邮箱: info@tawi.nl

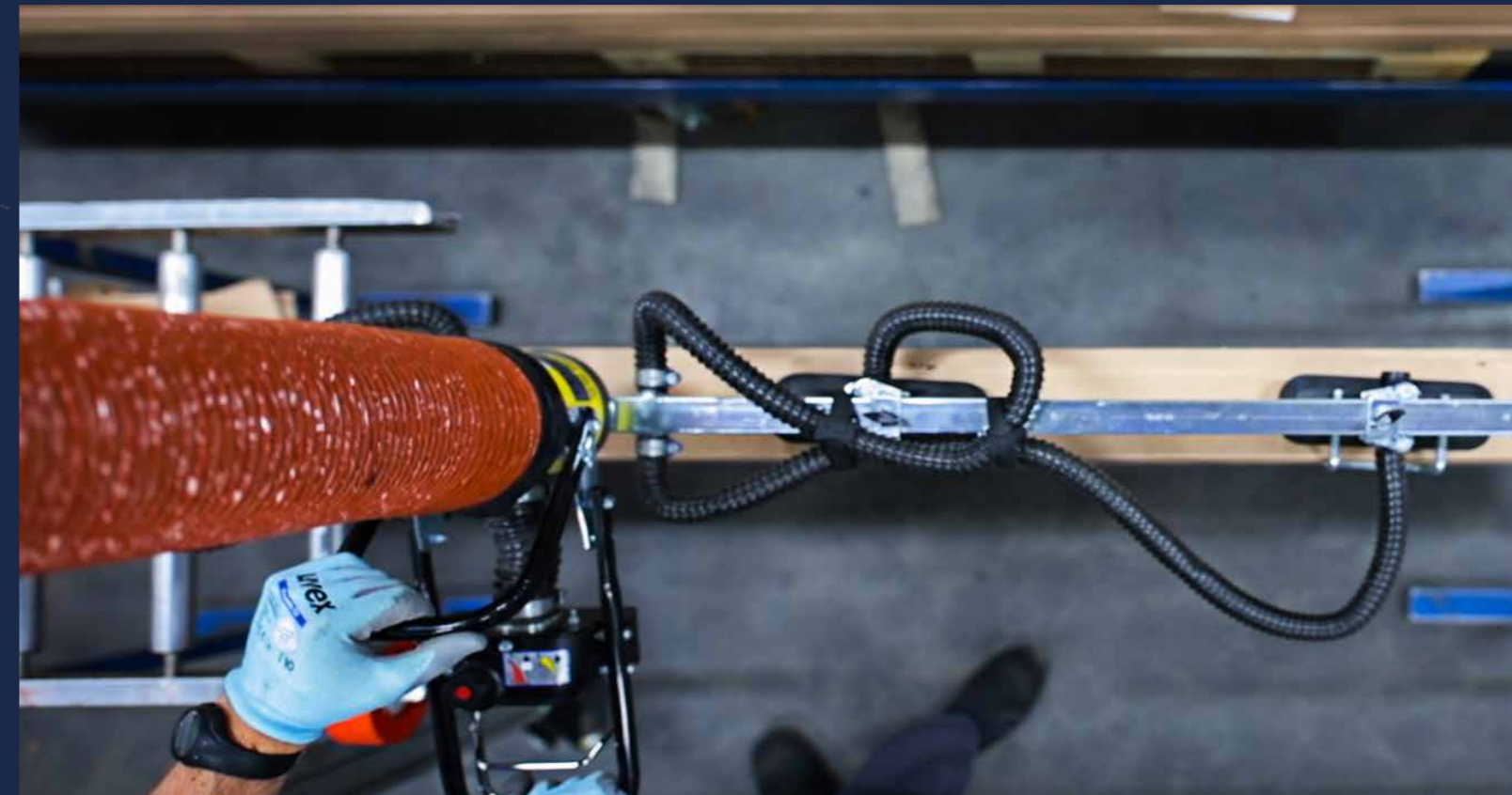

智捷搬运技术 高效人工操控

TAWI
Smart lifting

www.tawi.com

泰威
智捷搬运

www.tawi.com/cn

Lifting technology
for efficient manual handling

 始于1923年

目录CONTENTS

TAWI企业理念 TAWI Corporate Concepts	P01
--	------------

TAWI三位一体省钱之道 TAWI Equation	P02
-------------------------------	-----

真空搬运设备 Vacuum lifters	P03
---------------------------------	------------

TAWI威易力搬运设备 TAWI VacuEasylift	P04
----------------------------------	-----

TAWI威可力搬运设备 TAWI VacuCobra	P07
-------------------------------	-----

移动式搬运设备 Mobile lifters	P09
----------------------------------	------------

TAWI魔配客搬运设备 TAWI Mobile Order Picker	P10
---	-----

TAWI魔配客搬运设备—低架构 TAWI Mobile Order Picker - Low Built	P13
---	-----

TAWI普天马搬运手推车 TAWI Lifting Trolleys	P17
---------------------------------------	-----

工具与配件 Tools and accessories	P20
--------------------------------	-----

电动葫芦 Hoists	P21
-----------------------	------------

TAWI灵动提&TAWI泰然提 TAWI ViperHoist & TAWI Chain Hoist	P22
---	-----

TAWI真空夹具 TAWI Grip	P23
------------------------------	------------

TAWI真空夹具 TAWI Grip	P23
-----------------------	-----

起重机设备 Crane systems	P25
-------------------------------	------------

TAWI起重机设备 TAWI crane systems	P25
---------------------------------	-----



企业的长期成功关键 源于符合人机工程学的高效人工操控

孔斯巴卡, 瑞典西海岸的一颗明珠, TAWI总部在此集聚了一群专业人才, 我们的专业领域涵盖从产品开发到生产, 我们经验丰富的工程师团队, 可以根据您的需求度身定做搬运解决方案, 由手法娴熟的技术人员组合设备, 将工程师的设计带进现实, 在更短的时间内确保更好的品质。

我们的产品链从食品生产到汽车工业实现全面覆盖。我们将为每一位客户提供专业的服务, 会让您为选择我们的设备感到满意。选择TAWI产品, 给您带来全流程可靠的瑞典质量。

我们通过真空搬运设备、电动葫芦、起重机设备、移动式搬运设备, 使得我们从盒子到编织袋, 从奶酪到挡风玻璃, 无所不运。对于各类重型货物, 我们亦能灵巧搬运。还不快来体验下一站式服务的便捷。

- 现在就联系我们吧!



4008-066-012



salescn@tawi.com



www.tawi.com/cn

若有疑问, 请立即联系我们!

Efficient and ergonomic manual handling is key for long term business success

In Kungsbacka, a small town on the west coast of Sweden, TAWI head office is home to a dedicated staff, including everything from product development to production. Our team of experienced engineers design lifting solutions customized for your business needs. Their innovations are realised in the lifting equipment put together by skilled technicians, securing optimal quality and short lead times.

Dedicated customer support is guaranteed when investing in TAWI lifting solutions and our service team will assure that the equipment never fails you. Choosing TAWI means that you get Swedish quality and reliability, in product, service and support. We offer a wide selection of lifting solutions for everything from food manufacturing to automotive industry.

Our lifting equipment handles everything from boxes and sacks, to cheese and windshields. We can turn, tilt and rotate heavy barrels, large panels and much more. Our solutions include vacuum lifters, hoists, crane systems and mobile lifters. This means that TAWI equipment cover all your lifting needs. Experience the benefits of using one complete supplier.

- Contact us today.



+46 (0) 300 185 00



info@tawi.com



www.tawi.com

Any questions? Contact TAWI directly

TAWI 给您省钱

更高的生产效率

智捷搬运技术提升了生产效率。花更少的时间搬运更多的货物，始终保持工作效率。当搬运变得轻松，企业在发展中更能四两拨千斤。



更快乐的工作状态

将员工从繁重的搬运工作中解放出来，利于其在工作时保持快乐和高效。这样，您的员工将乐于以更高的工作状态追求更佳的工作质量。

更强的可操作性

高矮胖瘦，在TAWI智捷搬运技术前人人平等。TAWI让每位员工成为“大力士”，企业不再面临“缺角”困境。



三位一体，即是TAWI模式

更高的生产效率、更快乐的工作状态、更强的可操作性使得成本更低、操作更人性化，这就是TAWI模式给您带来的省钱之道。

中国区联系方式：4008-066-012或salescn@tawi.com

Save money with TAWI

Higher productivity and...

Increase productivity by making lifting easy. Lift more without losing speed and maintain productivity all day, every day. When lifting is easy you can lift more, with less effort.

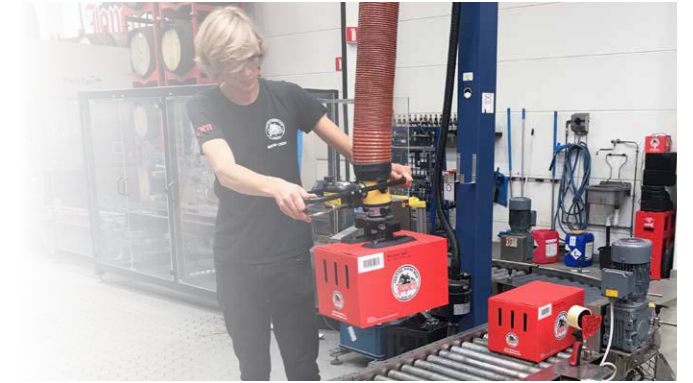

healthier employees and...

Relieve employees from strenuous lifting and help them stay healthy, alert and efficient all day. Your staff will be healthier and feel better, they will manage demanding work for long hours and still have energy for more.

workforce flexibility...

Big and strong or small and slender. It doesn't matter, anyone can lift. Streamline your operations by giving everyone the power to lift. Create a flexible workplace where employees can move between workstations to avoid unnecessary downtime and ensure continuous productivity.



...come together as the TAWI equation

Higher productivity, healthier employees and greater workforce flexibility equals a cost effective and ergonomic work environment. That is how you save money with the TAWI equation.

HQ contact: +46 300 185 00 or info@tawi.com

用真空提速搬运

“男友力十足”的TAWI真空技术帮助每一个人轻松搬运，我们在设计它时都以客户为本，使得操作非常人性化，任何人都能在短时间内学会“与他相处”。

TAWI真空搬运技术可以分毫无伤的实现搬运。袋子、盒子、板材，无论您想搬运什么，我们都将为您度身定制相应的真空吸盘。

TAWI真空搬运设备可以使每个人毫不费力地举起重达270kg的重物，使得员工岗位切换更为灵活。搬运机的用途极其广泛，简单的箱子到复杂的汽车部件等所有东西都可以处理。

TAWI**威易力**专注于提升泛用性，粗糙的麻袋、易碎的玻璃、复杂的汽车零部件，均可轻松应对。TAWI**威可力**专注于提升搬运速度，是快速搬运产品的不二之选。

Speed up the manual handling of goods with vacuum

TAWI vacuum lifters are robust and reliable tools that make lifting easy, for everyone. Our lifters are always designed with the user in focus. The vacuum lifters are very user-friendly and anyone will learn how to use them within minutes.

Vacuum technology is ideal for secure lifting without risk of damaging the goods or the person lifting them. Grip the load with suction cups designed for the goods you need to lift, regardless if you are lifting sacks, boxes, sheets or something else.

TAWI vacuum lifters allow everyone to lift up to 270 kilos without effort. Giving everyone the power to lift increases workforce flexibility, making it easy for employees to switch between work stations. The lifters are extremely versatile, handling everything from simple boxes to complicated car components.

TAWI VacuEasylift is our most versatile lifter, andling everything from ungainly sacks to fragile glass sheets or complex car components.

TAWI VacuCobra is your high-speed choice, ideal for high frequency handling of packaged goods.

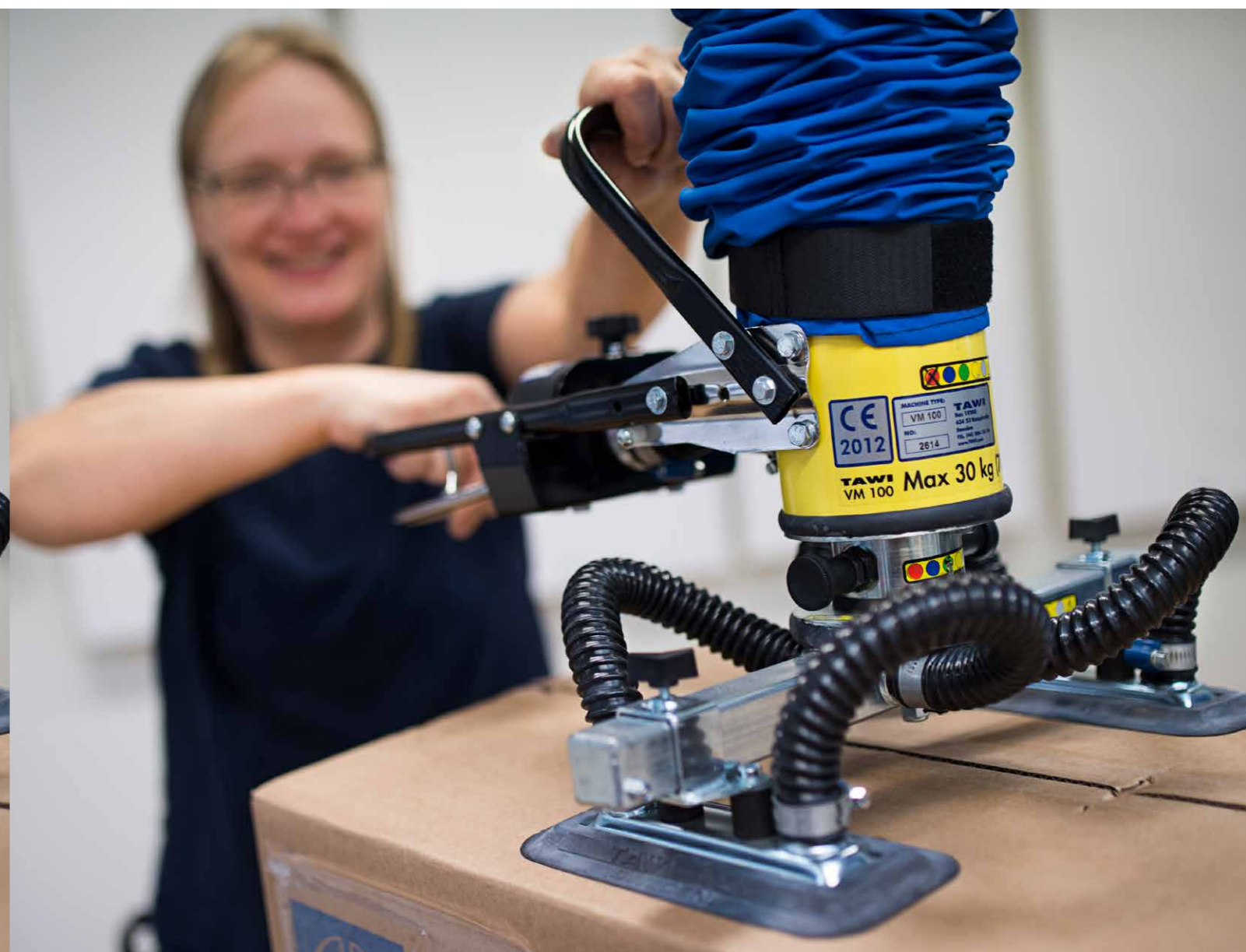
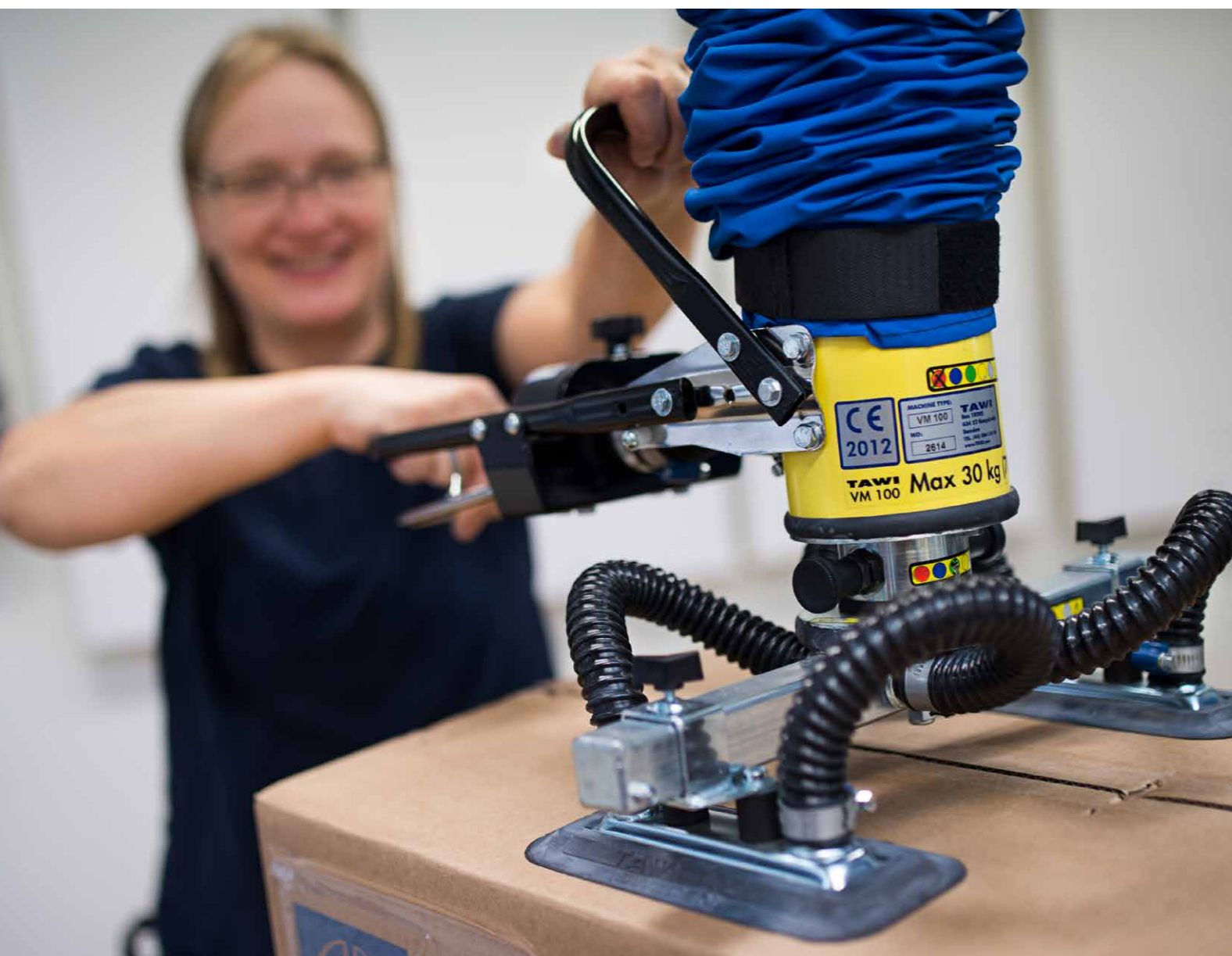

TAWI 威易力搬运设备

各类型箱式货物

- 工作流程快速、高效
- 抓取定位准确、可靠
- 可调节适配于各种箱子规格与形状
- 速度最快, 费力最少



Boxes and cartons

- Rapid, efficient workflow
- Accurate, secure grip and positioning
- Adjustability to suit various box sizes and shapes
- Maximum speed with minimal effort



各类袋装货物

- 大幅度地减少了繁重的搬运工作
- 能够抓牢每一个袋子, 令搬运高效、可靠
- 塑料袋、纸袋和编织袋
- 搬运时不损伤货物



Sacks and bags

- Drastic reduction in heavy, repetitive lifting
- Secure grip on every bag for efficient reliable lifting
- Tools for plastic, paper and woven sacks
- Lifting without damaging the sack

各类板材

- 可处理木板、玻璃板、铝板和层压板
- 能够抓牢板材, 令搬运高效、可靠
- 能够大范围移动, 具有最大的准确性与灵活性
- 倾斜或旋转角度可达到360°

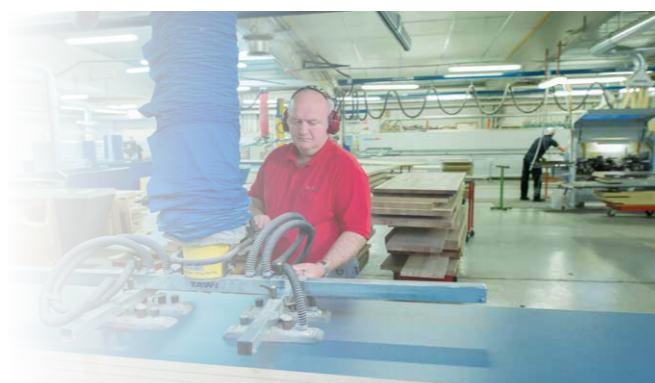

Sheets

- Handling sheets of wood, glass, aluminium and laminate
- Secure grip for efficient, reliable lifting
- Big range of movement for highest accuracy and flexibility
- Tilt or turn sheets up to 360°



各类桶、罐以及容器

- 从顶部或侧面抓牢
- 简单、人性化的手动操控
- 倾斜或旋转
- 一次可抓取并搬运多件货物



Drums, kegs and cannisters

- Grip from the top or from the side
- Easy and ergonomic manual handling
- Tools for tilting or rotating drums
- Grip and lift several drums or pails together

TAWI 威易力搬运设备的标准型号

型号	VM30	VM40	VM50	VM60
升降能力	30 kg	40 kg	50 kg	60 kg
升降管最大长度	2 500 mm	2 500 mm	2 500 mm	4 000 mm
升降管直径	100 mm	120 mm	140 mm	160 mm
冲程	1 800 / 2 600 mm	1 800 / 2 600 mm	1 800 / 2 600 mm	1 800 / 2 600 mm
升降速度	0-1 m/s	0-1 m/s	0-1 m/s	0-1 m/s

型号	VM80	VM100	VM120	VM180	VM270
升降能力	80 kg	100 kg	120 kg	180 kg	270 kg
升降管最大长度	4 000 mm	2 500 mm	4 000 mm	2 500 mm	2 500 mm
升降管直径	180 mm	200 mm	230 mm	250 mm	300 mm
冲程	1 800 / 2 600 mm	1 700 / 2 400 mm	1 700 / 2 400 mm	1 500 / 1 800 mm	1 500 / 1 800 mm
升降速度	0-1 m/s	0-1 m/s	0-1 m/s	0-1 m/s	0-1 m/s

VM30-VM120 型为不锈钢制造, 适合于卫生要求高的行业; VM180 与 VM270 型为不锈钢制造, 配标准软管。



真空泵

我们建议与起重设备一起同时安装 TAWI 威易力搬运机。悬臂式起重机或桥式起重机有悬浮升降管, 不同长度和能力的悬臂式起重机或桥式起重机可供选择。

关于 TAWI 起重机设备的更多信息见第 26-27 页。

我们的真空泵设计时考虑了三大要素: 性能、稳定性和持久性。直接驱动型真空泵尽量减少了摩擦和不必要的磨损, 确保您的真空搬运设备能够持续工作。

TAWI 真空泵有两种型号: 中型和大型。建议中型真空泵用于 VM30-50 型升降机, 大型真空泵用于 VM60-270 型升降机。



中国区联系方式: 4008-066-012 或 salescn@tawi.com

TAWI VacuEasylift standard models

Model	VM30	VM40	VM50	VM60
Lifting capacity	30 kg	40 kg	50 kg	60 kg
Max length lift tube	2 500 mm	2 500 mm	2 500 mm	4 000 mm
Lift tube ø	100 mm	120 mm	140 mm	160 mm
Stroke	1 800 / 2 600 mm	1 800 / 2 600 mm	1 800 / 2 600 mm	1 800 / 2 600 mm
Lifting speed	0-1 m/s	0-1 m/s	0-1 m/s	0-1 m/s

Model	VM80	VM100	VM120	VM180	VM270
Lifting capacity	80 kg	100 kg	120 kg	180 kg	270 kg
Max length lift tube	4 000 mm	2 500 mm	4 000 mm	2 500 mm	2 500 mm
Lift tube ø	180 mm	200 mm	230 mm	250 mm	300 mm
Stroke	1 800 / 2 600 mm	1 700 / 2 400 mm	1 700 / 2 400 mm	1 500 / 1 800 mm	1 500 / 1 800 mm
Lifting speed	0-1 m/s	0-1 m/s	0-1 m/s	0-1 m/s	0-1 m/s

VM30-VM120 are available in stainless steel, ideal for industries with high sanitary requirements. VM180 and VM270 are available in stainless steel with standard hose.



Vacuum pumps

We recommend mounting your TAWI VacuEasylift in our own range of crane systems. The jib arm or bridge crane suspends the lift tube and is available in different lengths and capacities.

Find more information about TAWI crane systems on pages 26-27.

Our vacuum pumps are designed with three key features in mind; performance, reliability and sustainability. The direct driven pump minimizes friction and unnecessary wear, ensuring continuous operations for your vacuum lifters.

TAWI vacuum pumps are available in two models; medium and large. The medium model is recommended for VM30-50, the large model for VM60-270.



HQ contact: +46 300 185 00 or info@tawi.com

把手



固定把手



标准把手



弯曲把手



特殊把手

Handles



Fixed handle



Standard handle



Flex handle



Special handle

吸盘

固定把手及特殊吸盘
630200标准把手及袋子吸盘
630300固定把手及钩子工具
630460弯曲把手及箱子吸盘
630650Fixed handle with
special suction foot
630200Standard handle
with suction foot for
sacks 630300Fixed handle with
hook tool 630460Flex handle with
suction foot for
boxes 630650固定把手及吸盘
610650弯曲把手及卷筒吸盘
610400固定把手及袋子吸盘
610320弯曲把手及吸盘
610700Fixed handle with
suction foot 610650Flex handle with
suction foot for reels
610400Fixed handle with
suction foot for
sacks 610320Flex handle with
suction foot 610700弯曲把手及侧升降吸盘
610850弯曲把手及升降板材用
的特制蜘蛛爪弯曲把手及板材角度
吸盘 610620
适配接头610810和
角度适配接头把手
610811桶吸盘
650210Flex handle with
suction for side
lifting 610850Flex handle with
special spider yoke
for lifting sheetsFlex handle with
suction foot for
sheets 610620, angle
adapter 610810, and
handle for angle
adapter 610811Suction foot for
drums 650210

TAWI 威可力搬运设备

TAWI VacuCobra

频率快

- 高速箱子搬运
- 从顶部或侧面抓取箱子
- 人性化的操控杆手柄可实现单手搬运
- 适合于左右单手操作用户



High speed handling

- High-speed box handling
- Grip boxes from the top or from the side
- One-handed lifting with user-friendly joystick handle
- Suitable for left- and right-handed users



时效高

- 单手便捷、轻松地拾取货物
- 快速、简单地释放货物



Time-efficient

- Easily pick up load with one hand
- Quick and easy release of load

符合人机工程学的人性化设计

- 舒适的操纵杆手柄, 操作方便
- 避免了人工的过度重复搬运操作
- 不需要旋转吊杆就能轻松转动重物,
- 并能做到精准有效
- 符合人体工程学设计确保了作业的安全



Ergonomic and user-friendly

- Comfortable joystick handle for easy operations
- Saves workers from straining repetitive lifting
- Rotate the load without rotating the lifter and handle goods with great accuracy
- Ergonomic design ensures a safe and ergonomic working position



处理箱子等货物

- 利用真空抓取货物, 抓取安全无损伤
- 各种吸附工具可以快速处理箱式、桶装、袋装等
- 其他货物

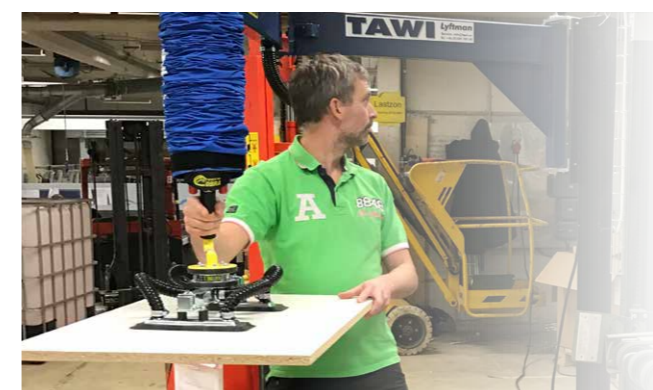

Handling boxes and more

- Gripping load with vacuum for a safe grip that does not damage the load
- Various suction tools allow quick handling of cartons, pails, sacks and more

TAWI 威可力搬运设备的标准型号

型号	VC20	VC35	VC40	VC50
升降能力	20 kg	35 kg	40 kg	50 kg
升降管最大长度	2 100 mm	2 100 mm	2 100 mm	2 100 mm
升降管直径	80 mm	100 mm	120 mm	140 mm
冲程	1 680 mm	1 6150 mm	1 615 mm	1 590 mm
升降速度	0-1 m/s	0-1 m/s	0-1 m/s	0-1 m/s



高速手动操控从未如此简单。我们利用可靠的真空技术，仅单手便可快速、简单地抓取和搬运。

TAWI 威可力搬运机可便利地安装在一个TAWI 变型臂上，或安装在较大工作区的TAWI 随型架上。运作过程中不会有空气软管的干扰，这样可以高效作业。我们将乐意为您提供指导，同时为您选择最合适的安装方案。

TAWI VacuCobra standard models

Model	VC20	VC35	VC40	VC50
Lifting capacity	20 kg	35 kg	40 kg	50 kg
Max length lift tube	2 100 mm	2 100 mm	2 100 mm	2 100 mm
Lift tube \varnothing	80 mm	100 mm	120 mm	140 mm
Stroke	1 680 mm	1 6150 mm	1 615 mm	1 590 mm
Lifting speed	0-1 m/s	0-1 m/s	0-1 m/s	0-1 m/s



High-speed manual handling has never been easier. Grip and lift quick and easy with just one hand, powered by reliable vacuum technology.

TAWI VacuCobra is conveniently mounted in a TAWI Jib Crane or for larger working areas, in a TAWI Overhead Bridge Crane. The air hose is held out of the way so that you can work efficiently without any disturbance. Your local TAWI representative will be happy to guide you to the best mounting solution for your lifter.

TAWI 威可力搬运设备选择

所有的TAWI 威可力搬运机均为不锈钢制造，搬运过程干净无污染。不锈钢型搬运机通常用于食品生产，可安全搬运奶酪块、冻肉、牛奶盒以及红酒盒等。可根据您的特殊要求选择合适的吸盘，确保搬运机能够抓取在不同位置的产品。



VC35 不锈钢

VC35 及标准吸盘

VC35 及适配接头

TAWI VacuCobra options

All TAWI VacuCobra models are available in stainless steel execution, a safe choice when lifting in environments with high demands on cleanliness. The stainless steel models are often used in food production, safely handling blocks of cheese or frozen meat, milk cartons, wine boxes and more. The suction feet can be adapted to meet your specific requirements, ensuring that the lifter is ideal for gripping your goods, no matter what they are.



VC35 stainless steel

VC35 with standard suction head

VC35 with adapter

用机动和灵活提升人性化

TAWI移动式搬运设备使您随心所欲的抓取、运输、放置任何货物。

TAWI**魔配客**具有独特的设计,可以高效处理及搬运货物,它可装载于各类叉车上,移动至作业地点。

TAWI**普天马**可轻松的在流水线上进行搬运作业,更可进行流动的简单搬运,通过各类配件可使此款便携设备有针对性的搬运各种不同形状的货物。

由于深知灵活度、机动力的重要性,除了搬运功能之外,我们给他们增加了倾斜及旋转货物的功能,轻松实现例如水平或垂直的倾斜圆桶,从而将其安装在机器轴上,或是倾斜圆桶或板条箱,从而倒出里面的货物。

Ergonomic lifting with full mobility and flexibility

TAWI mobile lifters allow you to lift anything, anywhere. Pick up goods in one place, transport them effortlessly, and lift them in place wherever you need them.

TAWI Mobile Order Picker is a unique solution for efficient order picking and material handling. Simply pick up the mobile vacuum lifter unit with any kind of forklift or pallet jack and go wherever you need to lift.

TAWI Lifting Trolleys are ideal for moving goods to and from a production line, or simply lifting without being confined to just one work station.

A variety of tools make these portable devices suitable for lifting different types of goods, including reels, drums and crates.

We know the importance of flexibility and mobility and that is why our lifting trolleys do not only lift but also rotate, turn and tilt goods. Reels are tilted from vertical to horizontal position before they are conveniently mounted on a machine axis. Drums and crates are easily tilted to empty their contents with no physical effort for the operator.



TAWI 魔配客移动式搬运设备

搬运货物多样

- 纸箱、盒子
- 纸袋、塑料袋和编织袋
- 木板、金属板、玻璃板或塑料板
- 桶、罐或容器
- 轮胎
- 其他货物



Lift anything

- Cartons and boxes
- Paper, plastic and woven sacks
- Sheets of wood, metal, glass or plastic
- Drums, kegs or cannisters
- Tyres
- and more



搬运地点灵活

- 可将设备移动到任何您需要搬运操作的地方
- 与所有类型的叉车或液压车兼容
- 可调节高度, 能够进入托盘架或
- 其他狭窄空间其他货物



Lift anywhere

- Move the lifter anywhere you need to lift
- Compatible with any type of forklift or pallet jack
- Adjustable tower height allows reach into pallet racks or other low headroom areas

操作安全、人性化

- 符合人体工程学的人工操控设计
- 搬运时给予高稳定性的支撑
- 移动时, 安全锁能将关节臂固定在位置上
- 人性化控制面板
- 集成照明面板便于在黑暗场所工作



Safe and user friendly

- Designed for ergonomic manual handling
- Support legs for optimal stability when lifting
- Safety lock holds articulating arm in place when moving the lifter
- User friendly on-board panel
- Integrated light panel facilitates work in dark spaces

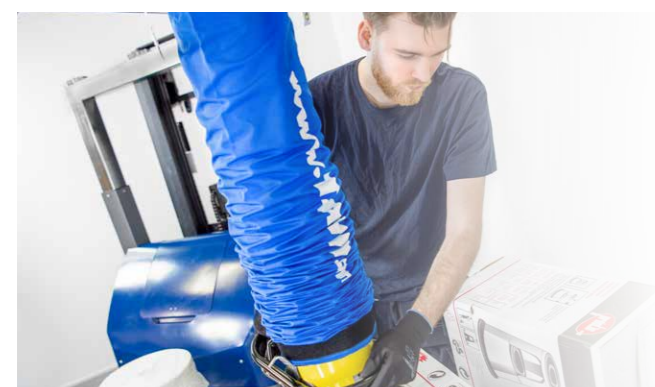

适配性强, 灵活多样

- 兼容各种真空搬运机与工具
- 可毫不费力地调整适用于任何叉车设备
- 电子自动调节高度, 适合不同搬运高度和高度限制



Flexible and versatile

- Compatible with various vacuum lifters and vacuum tools
- Adaptable fork tunnels for effortless adjustment to any fork system
- Electronically driven height adjustment to accommodate different lifting heights and height limitations

TAWI 魔配客移动式搬运设备技术参数

型号	VM40	VM50	VM60	VM80	VC40
升降能力	40 kg	50 kg	60 kg	80 kg	40 kg
升降管直径 (mm)	120	140	160	180	120
真空升降机冲程 (mm)	1340	1320	1320	1290	1230
冲程 (mm)	500	500	500	500	500
升降管长度 (mm)	1750	1750	1750	1700	1600
空闲噪声级 (dB)	76	76	76	76	76
操作噪声级 (dB)	75	75	78	78	76
最大升降高度*	1940	1920	1900	1890	1810
升降处于低位 (mm)	1440	1420	1400	1390	1310
电池充电规程	插入电气插座 (100-240 V. 对于110 V请使用三相充电器;对于230V, 请使用单相充电器。接地, 50-60 Hz) 建议8小时连续充电。				
电池组更换	更换电池组可延长工作时间, 完成这一程序大约需要10分钟。				
外部电源	该装置可连接到外部24V电源。				
升降速度	52-58 mm/s				
装置重量	630 kg				

* 自顶部吸盘底部 (不含底部吸盘)

TAWI Mobile Order Picker specifications

Model	VM40	VM50	VM60	VM80	VC40
Lifting capacity	40 kg	50 kg	60 kg	80 kg	40 kg
Lift tube ø (mm)	120	140	160	180	120
Stroke vacuum lifter (mm)	1340	1320	1320	1290	1230
Stroke tower (mm)	500	500	500	500	500
Lift tube length (mm)	1750	1750	1750	1700	1600
Noise level, idle (dB)	76	76	76	76	76
Noise level, in operation (dB)	75	75	78	78	76
Max lifting height*	1940	1920	1900	1890	1810
with lowered tower (mm)	1440	1420	1400	1390	1310
Battery charging procedure	Plug into an electrical outlet (100-240 V. For 110 V, use 3-phase charger. For 230 V, use single-phase charger. Grounded, 50-60 Hz) Recommended 8 hours continuous charge.				
Battery pack replacement	Prolonged operational time is achieved by switching the battery pack. This procedure takes approx. 10 minutes.				
External power source	The unit can be connected to a 24 V external power source.				
Up and down motions of tower	52-58 mm/s				
Weight of unit	630 kg				

* From bottom of suction head (excl. suction foot)

技术图

后面的图纸是TAWI 魔配客各种角度的技术图, 表中所列可以匹配不同型号真空搬运设备的尺寸。



	VM40	VM50	VM60	VM80	VC40
A*	150	149	132	156	130
B	1340	1320	1320	1290	1230
C*	1490	1469	1452	1446	1360
D	592	613	630	637	722
E	2 000	2 000	2 000	2 000	2 000
F	1100	1100	1100	1100	1100
G*	2 000	2 000	2 000	2 000	2 000
H*	2 080	2 080	2 080	2 080	2 080
I*	1850	1850	1850	1850	1850
J	1150	1150	1150	1150	1150
K	1710	1710	1710	1710	1710
L	1100	1100	1100	1100	1100
M	1130	1130	1130	1130	1130
N	470	470	470	470	470

* 所有尺寸单位为毫米

Technical drawings

Drawings on the following pages provide an overview of TAWI Mobile Order Picker in various perspectives. The table lists dimensions for the unit equipped with different vacuum lifter models.



	VM40	VM50	VM60	VM80	VC40
A*	150	149	132	156	130
B	1340	1320	1320	1290	1230
C*	1490	1469	1452	1446	1360
D	592	613	630	637	722
E	2 000	2 000	2 000	2 000	2 000
F	1100	1100	1100	1100	1100
G*	2 000	2 000	2 000	2 000	2 000
H*	2 080	2 080	2 080	2 080	2 080
I*	1850	1850	1850	1850	1850
J	1150	1150	1150	1150	1150
K	1710	1710	1710	1710	1710
L	1100	1100	1100	1100	1100
M	1130	1130	1130	1130	1130
N	470	470	470	470	470

* All measures are in millimeters.

侧视图

正视图

Side view

Front view

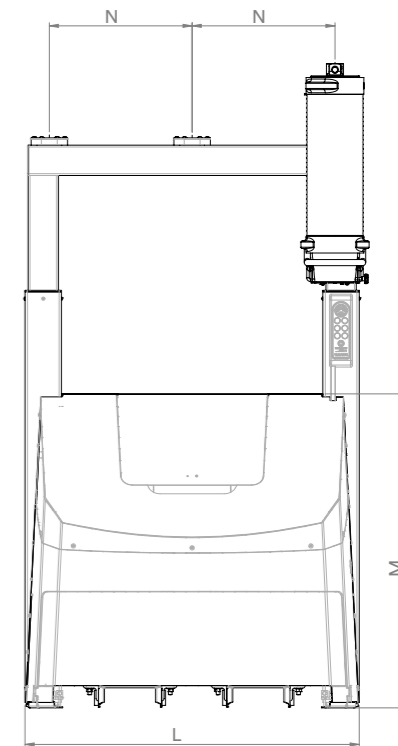
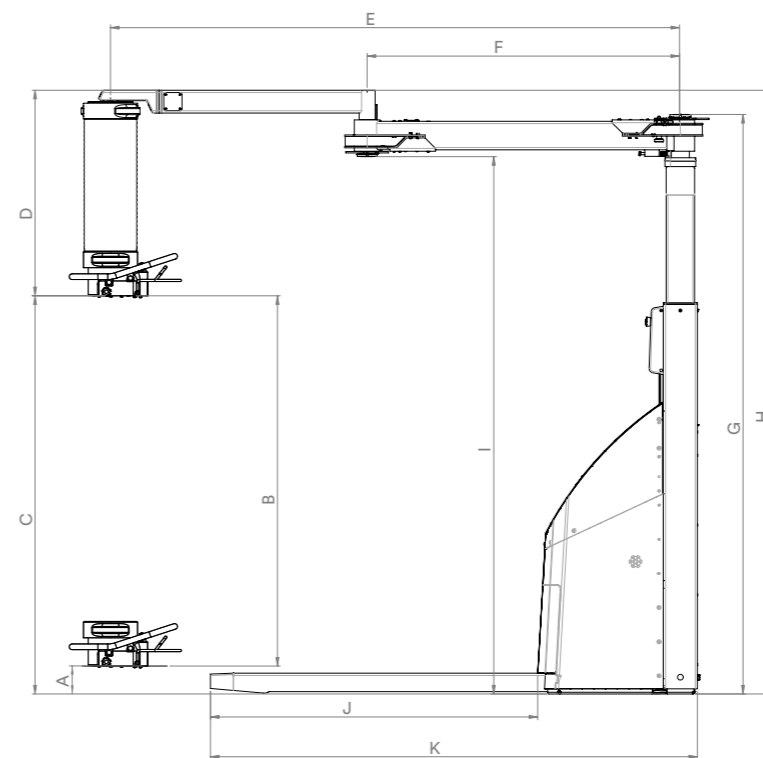
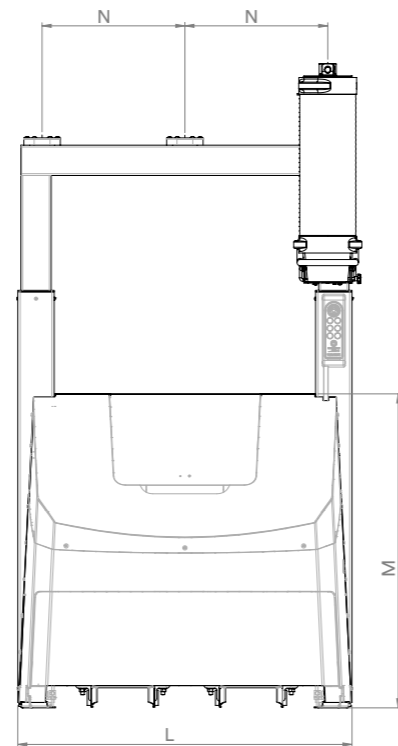
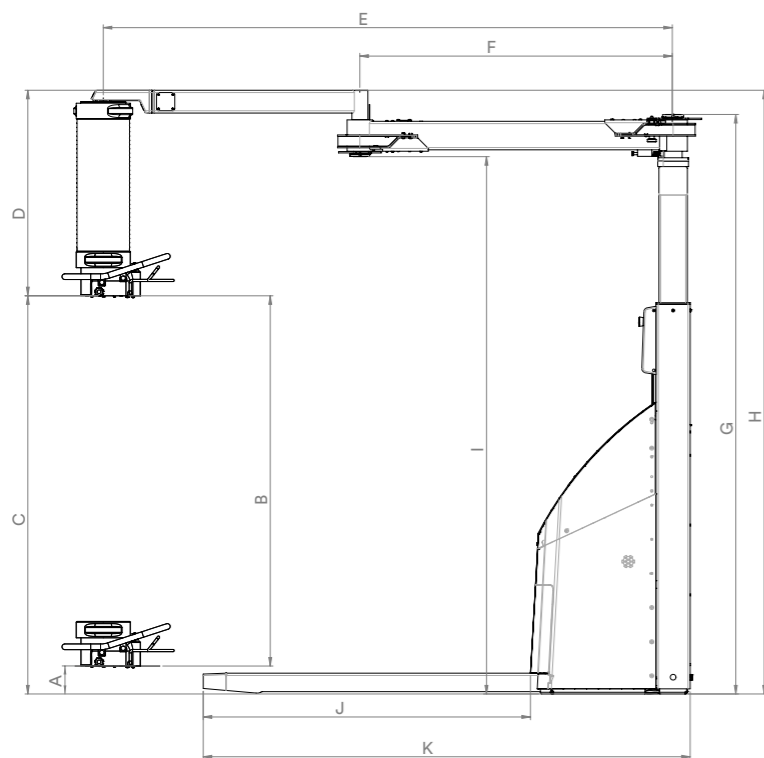

顶视图

Top view

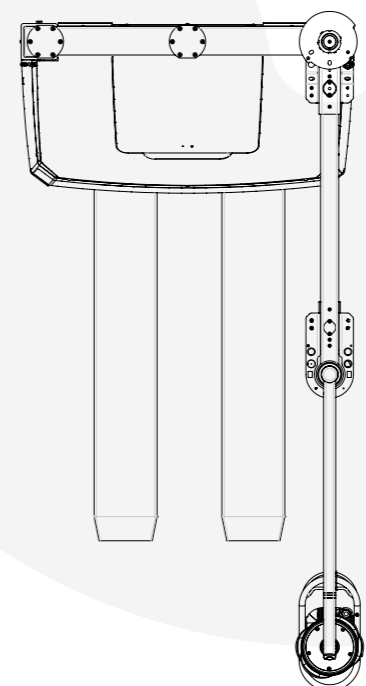
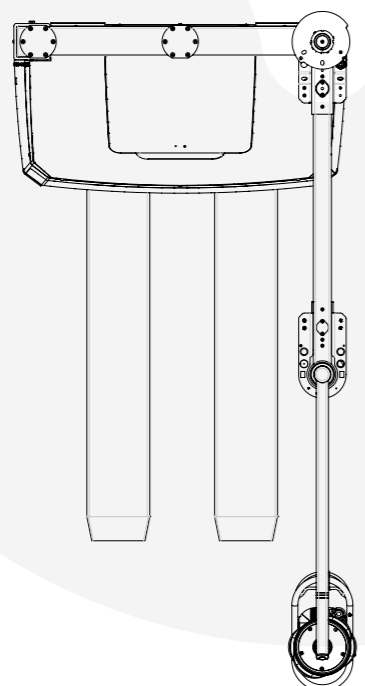

TAWI 魔配客移动式搬运设备 - 低架构



人性化手柄, 便于单手操作

- 符合人机工程学的人性化手柄
- 可单手抓取、提升、下降和释放货物
- 直接用手柄调节高度
- 单击即可启动或停止真空泵

电池与真空泵一体化

- 电池与真空泵集成在设备内
- 运转时间: 可连续恒定运转3小时
- 便于更换电池组
- 坚实的电池保护盖和板载电子器件

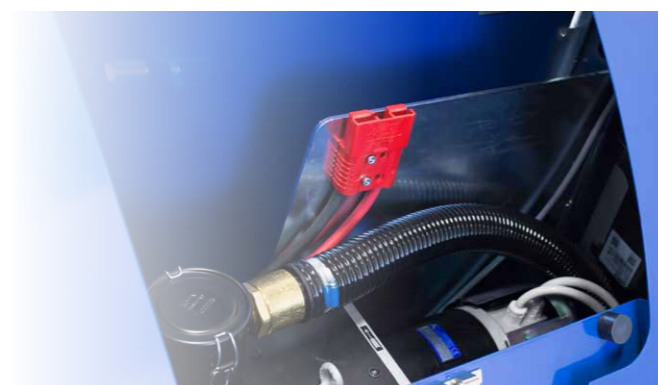

安全稳定的支撑

- 支撑腿自动启动
- 确保搬运时的稳定性
- 确保操作人员与运载货物的安全性



TAWI Mobile Order Picker - Low Built



Control all motion with one hand

- User-friendly ergonomic handle
- Grip, lift, lower and release loads with one hand
- Adjust the height of the tower directly on the handle
- Start and stop the vacuum pump with one click

Integrated battery and vacuum pump

- Battery and vacuum pump are integrated in the unit
- Operation time: 3 hours constant use
- Easy to switch battery pack
- Robust cover protecting battery and on-board electronics



Support legs for optimal safety

- Automatically activated support legs
- Ensure stability when lifting
- Maximum safety for operator and load



TAWI魔配客移动式搬运设备 - 低架构

TAWI Mobile Order Picker - Low Built

**无限可达**

低重心的TAWI魔配客可在顶部空间有限的情况下伸入托盘架、容器和其它区域。

由于设计非常紧凑，操作人员可顺利地把升降臂移入/移出托盘架，能够轻松取到托盘上的所有货物。

**Unlimited reach**

The low built TAWI Mobile Order Picker offers extended reach into pallet racks, containers and other areas with limited head room.

Due to the extremely compact design the operator can smoothly move the arm in and out of pallet racks, reaching all goods on a pallet from top to bottom.

低架构TAWI魔配客移动式搬运设备技术参数

	技术参数
升降能力	35 kg
可调高度	500 mm
电池充电规程	插入电气插座 (100-240 V。对于110 V请使用三相充电器;对于230V, 请使用单相充电器。接地, 50-60 Hz)建议8小时连续充电。
电池组更换	更换电池组可延长工作时间,完成这一程序大约需要10分钟。
外部电源	该装置可连接到外部24V电源。
升降速度	52-58 mm/s
装置重量	630 kg

TAWI Mobile Order Picker Low Built - technical specifications

	Specification
Lifting capacity	35 kg
Adjustable height	500 mm
Battery charging procedure	Plug into an electrical outlet (100-240 V. For 110 V, use 3-phase charger. For 230 V, use single-phase charger. Grounded, 50-60 Hz) Recommended 8 hours continuous charge.
Battery pack replacement	Prolonged operational time is achieved by switching the battery pack. This procedure takes approx. 10 minutes.
External power source	The unit can be connected to a 24 V external power source
Up and down motions of tower	52-58 mm/s
Weight of unit	630 kg



侧视图

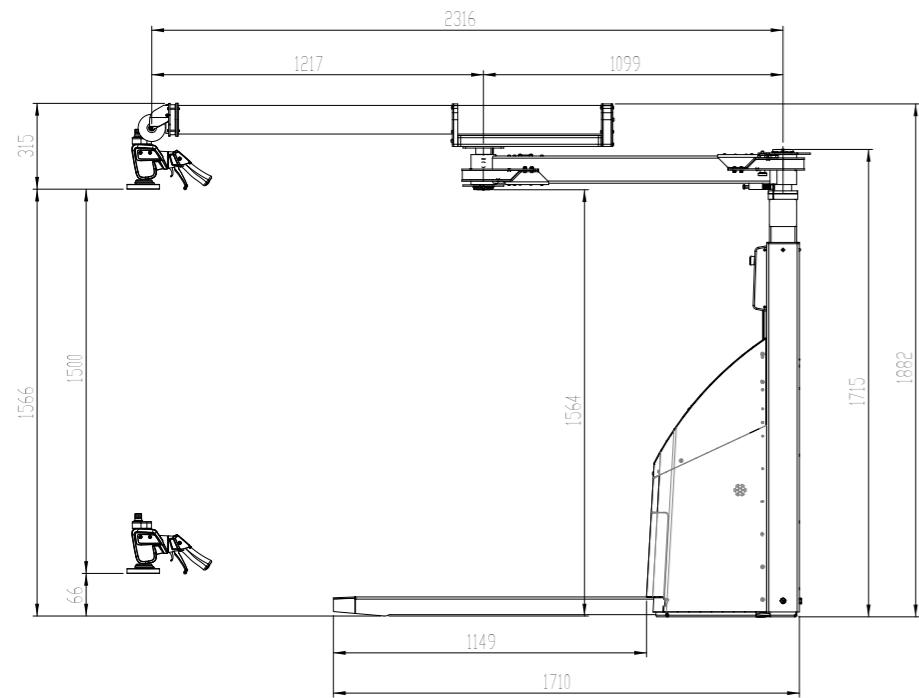

正视图

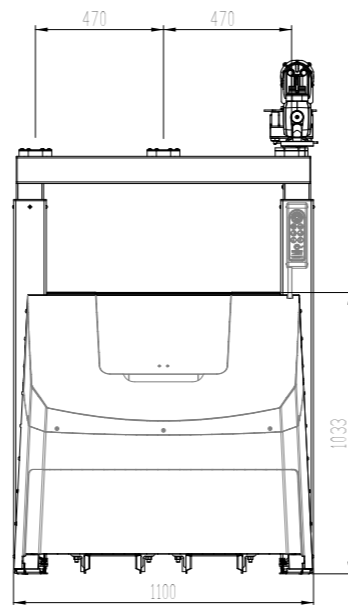

Side view

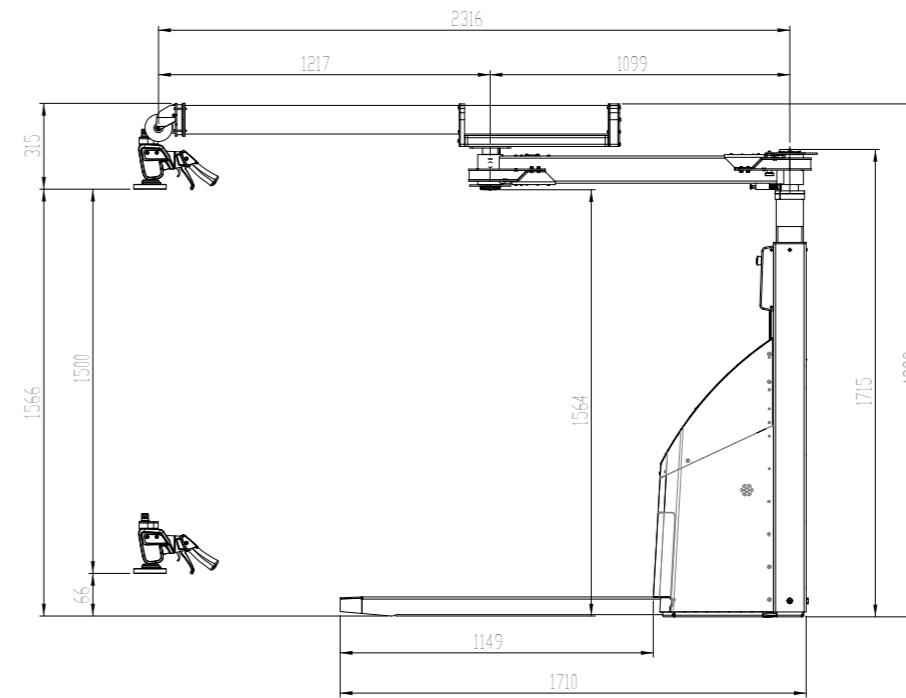

Front view

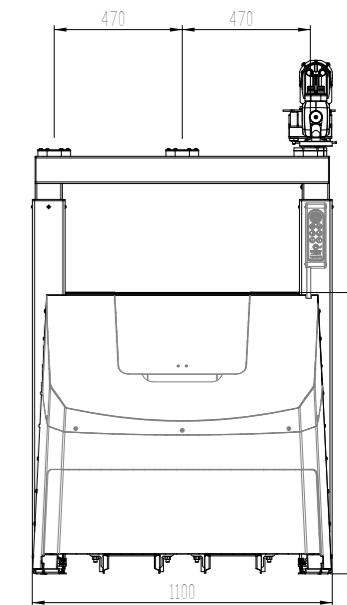

顶视图

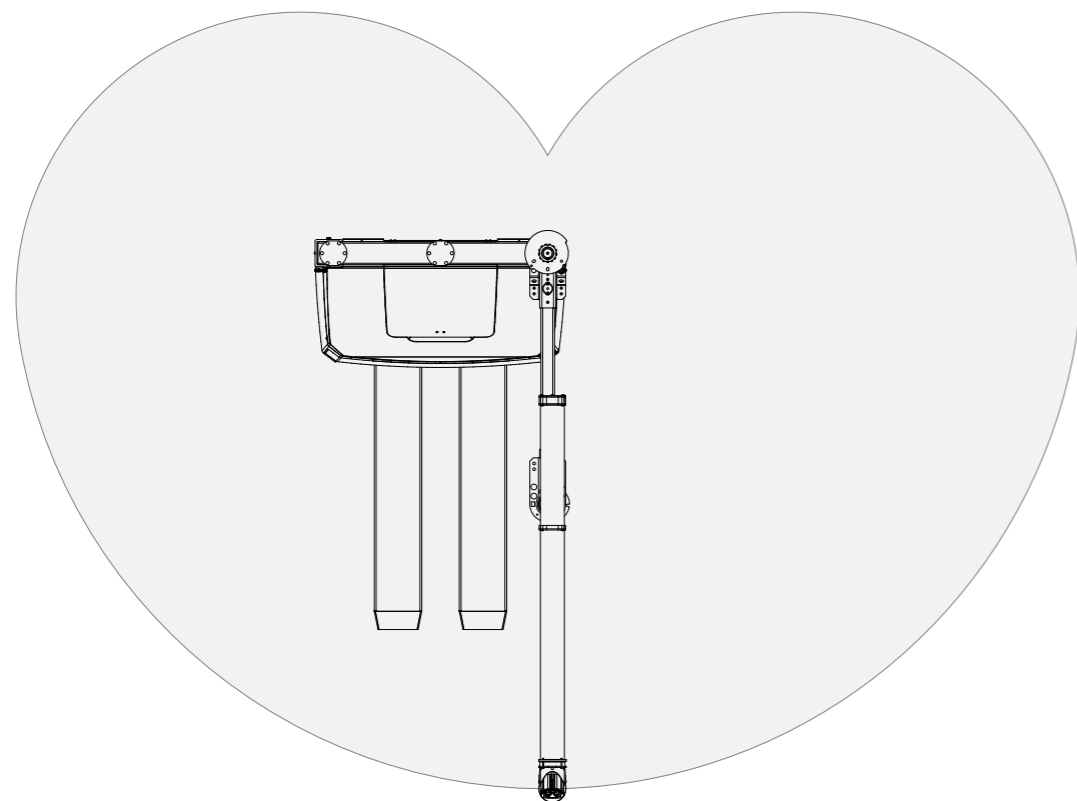

Top view

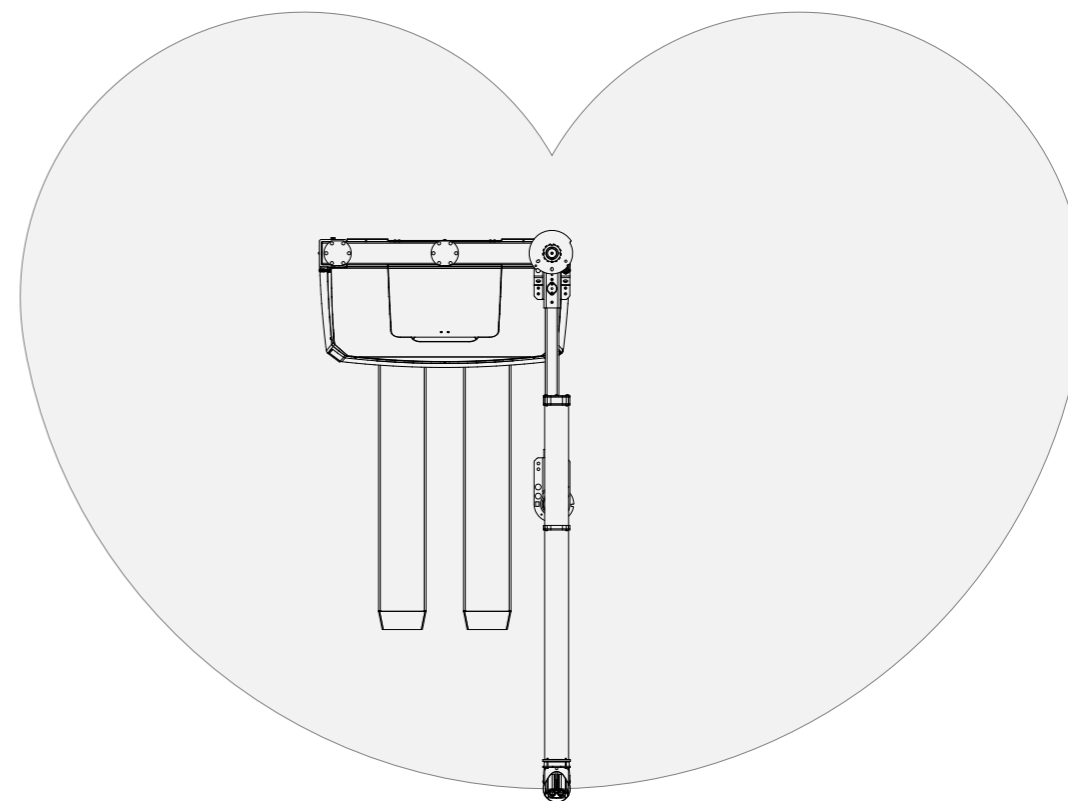

TAWI 普天马升降手推车

安全可靠

- SafeDrive能够确保在运作过程中撞到物体时可立即停顿
- 通过皮带驱动, 传动平稳无噪无油
- 所有机型均有速度控制和过载保护电路板



Safe and reliable

- SafeDrive ensures that if a tool hits an object during lowering, it will stop immediately
- The lifter is belt driven which ensures quiet and smooth oil free drive
- Circuit board for speed control and overload protection on all models



灵活多变

- 模块化结构, 可方便地调节升降器以适应各种场合
- 标准系列的搬运能力在40-250公斤之间
- 有几款型号的轮子尺寸使其能够以三种不同的方式驱动进入欧式托盘



Flexible

- Modular construction, making it easy to adjust the lifter for various applications
- The standard series have lifting capacities between 40-250 kg
- On several models, the measures of the wheels makes it possible to drive the lifter into a Euro-pallet in three different ways

符合人机工程学的人性化设计

- 最大限度地减少了背部、膝盖和肩膀的压力
- 人性化手柄操作简单、舒适
- 高质量和结实的轮子让空车和满载的运输顺畅、便捷



Ergonomic

- Minimizes the strain on back, knees and shoulders
- Ergonomic handle for easy and comfortable operation
- High quality and robust wheels for smooth and simple transportation with and without load



省时高效

- 操作轻松高效
- 可拆卸电池组方便更换电池无电缆
- 高效电池充电器, 充电时间短
- 充电指示灯清晰显示电池充电状态



Efficient

- Lift more with less effort
- Detachable battery pack makes it easy to switch batteries. No cables.
- Effective battery charger makes the full charging cycle fast
- Charging indicator clearly showing the battery charging status

TAWI 普天马搬运手推车

TAWI Lifting Trolleys

各种桅杆规格

各种长度满足您的要求

可拆分式手控

平滑拆分手控实现最佳操作

易于操作的控制面板

- 急停开关
- 集成的工装操作控制
- 检修指示器
- 电池状态显示

工具选择范围广

可方便操纵:

- 卷筒
- 桶装货物
- 板条箱
- 箱式货物
- 以及更多!

SmartPack高效的电池组解决方案

- 电池寿命长
- 可拆卸电池
- 电池更换方便
- 无电缆
- 高效充电器
- 电池状态指示灯

可靠的制动系统

中央三位制动:方向锁、空档与制动

Variable mast size

Variation of lengths to meet your requirements

User friendly control panel

- Emergency stop
- Integrated operation controls for tooling
- Service indicator
- Battery status display

Wide selection of tools

Easy handling of

- Reels
- Drums
- Crates
- Boxes

And much more!

Reliable braking system

Central brake with three positions: Directional lock, Neutral and Brake

Detachable hand control

Smoothly detached hand control for optimal operation

SmartPack - the efficient battery pack solution

- Long battery life
- Detachable battery
- Easy to switch batteries
- No cables
- Effective charger
- Battery status indicator

TAWI 普天马型号与技术参数



Model	PRO40	PRO80	PRO140	PRO180
升降能力	40kg	80kg	140kg	180kg
冲程 mm 短/中/长	-/1040/-	850/1400/1950	840/1390/1940	840/1390/1940
设备重量 kg短/中/长	-/41/-	46/50/53	69/73/78	77/ 81/86
设备总高度 mm 短/中/长	-/1640/-	1440/1990/2540	1440/1990/2540	1440/1990/2540
电池充电规程	100-240V, grounded 50-60 Hz	100-240V, 接地 50-60 Hz	100-240V, 接地 50-60 Hz	100-240V, 接地 50-60 Hz
每次充电后升降次数	40kg x 1m x 100 times	80kg x 1m x 100 次	140kg x 1m x 100 次	180kg x 1m x 100 次
上下动作	控制面板(单速)	手动控制(双速)	手动控制(双速)	手动控制(双速)
前轮	回转	回转	固定	固定
制动系统	后轮单独制动	中央制动器及方向锁	中央制动器及方向锁	中央制动器及方向锁
过载保护	含在电路负载中	含在电路负载中	含在电路负载中	含在电路负载中



型号	PRO250	PRO100ESE	PRO200ESE	Stainless steel
升降能力	250kg	100kg	200kg	
冲程 mm 短/中/长	-/1360/1910	-/1390/1940	-/1360/1910	
设备重量 kg短/中/长	-/107/113kg	-/115/120kg	-/152/158kg	不锈钢支脚、轮子与手柄。配备 FDA 认可的白色盖子。
设备总高度 mm 短/中/长	-/1990/2540	-/1990/2540	-/1990/2540	
电池充电规程	100-240V, 接地 50-60 Hz	100-240V, 接地 50-60 Hz	100-240V, 接地 50-60 Hz	PRO140-250 型可提供, 含 100ESE 和 200ESE。
每次充电后升降次数	250kg x 1m x 100 次	100kg x 1m x 100 次	200kg x 1m x 100 次	
上下动作	手动控制(双速)	手动控制(双速)	手动控制(双速)	技术参数见各自型号。
前轮	固定	固定	固定	
制动系统	中央制动器及方向锁	中央制动器及方向锁	中央制动器及方向锁	
过载保护	含在电路负载中	含在电路负载中	含在电路负载中	

Models and technical details



Model	PRO40	PRO80	PRO140	PRO180
Lifting capacity	40kg	80kg	140kg	180kg
Stroke mm short/medium/long	-/1040/-	850/1400/1950	840/1390/1940	840/1390/1940
Weight of unit kg short/medium/long	-/41/-	46/50/53	69/73/78	77/ 81/86
Total height of unit mm short/medium/long	-/1640/-	1440/1990/2540	1440/1990/2540	1440/1990/2540
Battery charging procedure	100-240V, grounded 50-60 Hz	100-240V, grounded 50-60 Hz	100-240V, grounded 50-60 Hz	100-240V, grounded 50-60 Hz
Lifts per charge	40kg x 1m x 100 times	80kg x 1m x 100 times	140kg x 1m x 100 times	180kg x 1m x 100 times
Up and down motions	Control panel (one speed)	Hand control (two speed)	Hand control (two speed)	Hand control (two speed)
Front wheels	Swivelling	Swivelling	Fixed	Fixed
Brake system	Rear wheels separately braked	Central brake with directional lock	Central brake with directional lock	Central brake with directional lock
Overload protection	Incorporated in circuit load	Incorporated in circuit load	Incorporated in circuit load	Incorporated in circuit load



Model	PRO250	PRO100ESE	PRO200ESE	Stainless steel
Lifting capacity	250kg	100kg	200kg	
Stroke mm short/medium/long	-/1360/1910	-/1390/1940	-/1360/1910	
Weight of unit kg short/medium/ long	-/107/113kg	-/115/120kg	-/152/158kg	Legs, wheels and handle in stainless steel. Equipped with a white FDA approved cover.
Total height of unit mm short/medium/long	-/1990/2540	-/1990/2540	-/1990/2540	
Battery charging procedure	100-240V, grounded 50-60 Hz	100-240V, grounded 50-60 Hz	100-240V, grounded 50-60 Hz	Available for models PRO140-250 including 100ESE and 200ESE.
Lifts per charge	250kg x 1m x 100 times	100kg x 1m x 100 times	200kg x 1m x 100 times	
Up and down motions	Hand control (two speed)	Hand control (two speed)	Hand control (two speed)	For technical details see separate model.
Front wheels	Fixed	Fixed	Fixed	
Brake system	Central brake with directional lock	Central brake with directional lock	Central brake with directional lock	
Overload protection	Incorporated in circuit load	Incorporated in circuit load	Incorporated in circuit load	

工具与配件



TAWI 易福来可以按指定需求调节支脚的度。

PRO80 和 PRO140型的支脚也可以方便地调节宽度, 每个支脚可调节150mm。

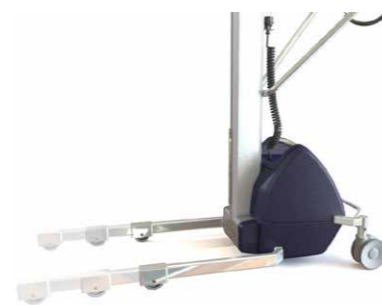

Tools and accessories

With EasyFlex we can adjust the length of the legs according to your specific needs.

On models PRO80 and PRO140 the legs can also easily be adjusted in width, each leg is adjustable by 150mm.



平台

人性化处理各种产品双面材料: 不锈钢与网纹钢板。



管叉

可从卷筒外表面轻松处理卷筒。



折叠平台

挠性工具及折叠平台与叉具, 用同样的工具升降纸箱与板条箱。



起重臂与起重钩

各种产品的操作进入狭窄空间的工具。



Platform

Ergonomic handling of various goods. Two surface materials: stainless steel and checker plate.



Fold up platform

Flexible tool with fold up platform and fork tool. Lift boxes and crates with the same tool.



Boom

Ergonomic reel handling. Lift and transport reels onto shafts and machines without effort.

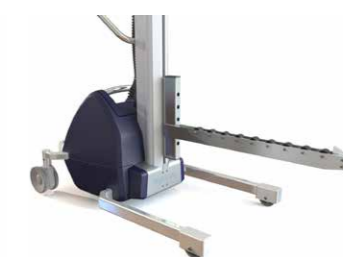

Roller boom

Equipped with rollers for effortless loading and unloading of reels. Safety pin for safe transportation.



动臂

人性化卷筒操作轻松抬起卷筒并把卷筒输送到轴和机器上。



轴叉

精确操纵轴上的卷筒送入机器。



辊式动臂

配备了辊子, 可轻松装卸卷筒, 安全销保证安全运输。



提芯器

处理芯直径76和152的卷筒, 从水平位置转动到垂直位置。



Tube fork

Easy handling of reels from their outer surface.



Crane arm with hook

Handling of various goods. Optimal for reaching into narrow spaces.



Fork for shafts

Precise handling of reels on shafts into machine.



Core gripper

Reel handling from the core, Ø76 and Ø152. Rotate from vertical to horizontal position.



梯子

便于把产品从工具推到架子上, 可安装在升降机的两侧。

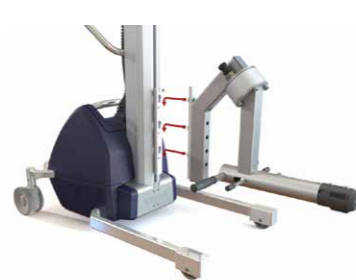

快速连接

方便在升降机上更换工具。



关节式适配接头

方便工具的连接, 可安装在各种类型工具之间。



Ladder

Optimal for pushing goods from the tool onto a shelf. Can be mounted on both sides of the lifter.

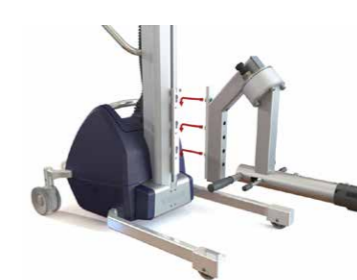

Quick coupling

Makes it possible to easily switch tools on the lifter.



Articulating adapter

Enables easy articulation of tools. Can be mounted between all types of tools.

精准有力的搬运各类货物

当您想平稳搬运重物时, 电动葫芦将是您的理想选择, 它尤其擅长搬运各类重型货物或金属形态。

TAWI灵动提是电动葫芦市场中兼顾速度与精确性的领先产品。丰富的可选用配件使其可以搬运从编织袋到金属配件的各类货物, 它的人体工程学设计及易用性使您实现单手操作, 可变速度控制让您随意控制搬运速度, 在搬运过程中, 全程精确控制。

TAWI泰然提偏重大型货物, 最高承载2500公斤, 即使在恶劣的环境下, 它亦能体现其安静和持久的特性。这种结实耐用的产品在户外亦能正常发挥。

电动葫芦安装简单, 保养轻松。我们的产品质量好, 能耗低, 经久耐用, 拥有成本低。是省时省力提升手工处理货物行之有效的好方法。

Lifting all types of goods with precision and power

An electric hoist is ideal when you need to lift with stability and control. Perfect for handling cumbersome containers, tall metal profiles and much more.

TAWI ViperHoist is among the fastest hoists on the market, lifting with both speed and precision. A wide selection of tools makes it possible to lift anything from woven sacks to metal profiles. A user-friendly and ergonomic handle makes the hoists easy to control with just one hand. Variable speed control allows you to choose how fast or slow you need to move at any point, giving you full control and precision when lifting.

TAWI Chain Hoist lets you handle heavier loads, up to 2 500 kg. The chain hoist is characterized by its silent run and long durability, even in very tough conditions. This strong and durable hoist is even suitable for outdoor use.

The electric hoists are easy to install and require little maintenance. High quality and low energy consumption makes the hoist a sustainable choice with low cost of ownership. Simply a great way of streamlining manual handling of goods and saving both time and money.

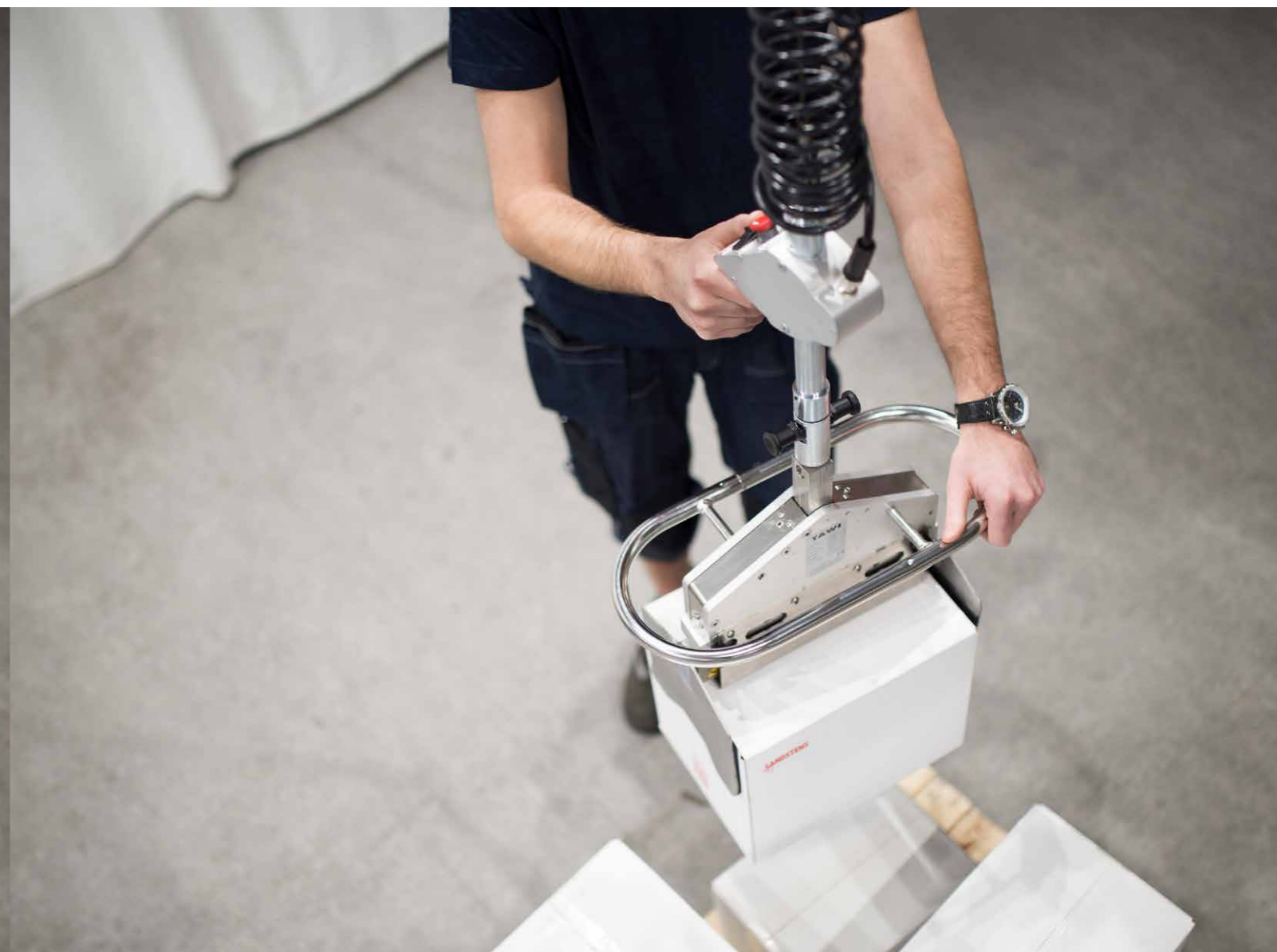
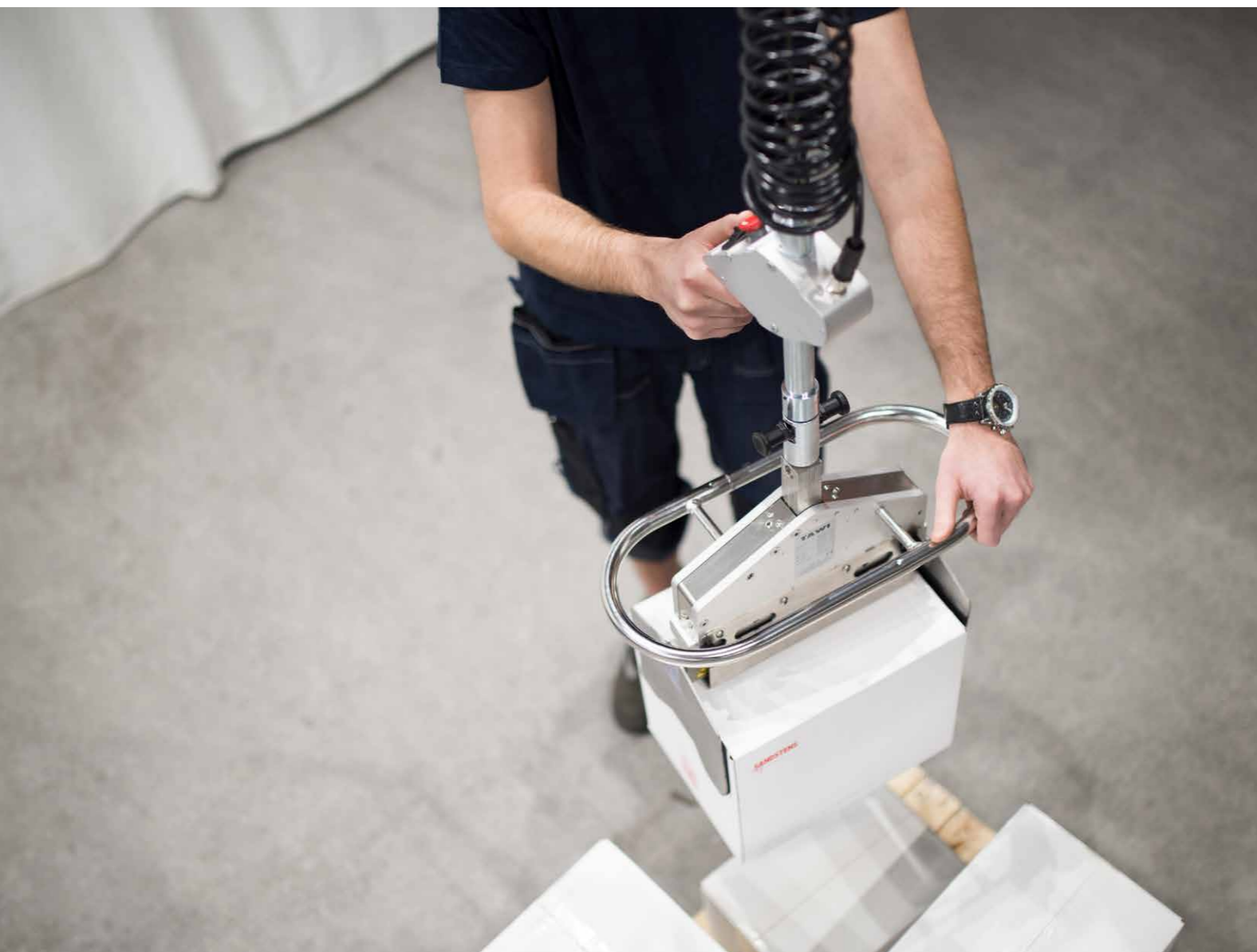

TAWI 灵动提电动葫芦 & TAWI 泰然提电动葫芦

适用各种应用工具

- 卷筒
- 金属型材
- 汽车部件
- 电池
- 罐、桶
- 托盘
- 各种袋装货物

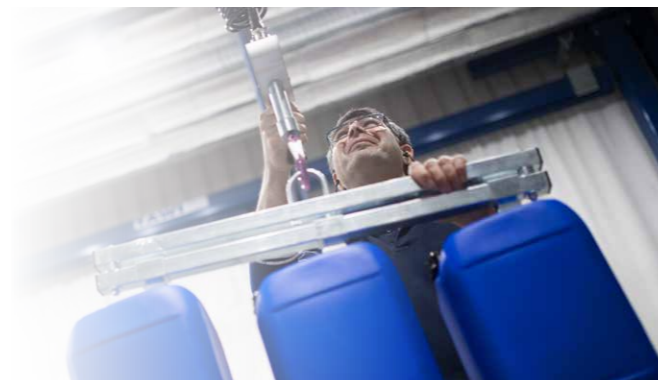

高速、高效

- 速度达到0.75米/秒
- 变速控制
- 人性化的手柄, 使电动葫芦操作简单、高效
- 快速连接, 可快速更换工具
- 升降能力60/120 kg (钢丝绳电动葫芦)



经济、耐用

- 能耗低
- 拥有成本低
- 安装简单, 几乎不需要维护



大型链式电动葫芦

- 升降能力<2 500 kg
- IP65, 适合室外使用
- 链安全系数至少8倍 (FEM, 2m, ISO, M5)
- 耐磨DC弹簧负载制动器



TAWI ViperHoist & TAWI Chain Hoist

Tools for various applications

- Reels
- Metal profiles
- Car components
- Batteries
- Cannisters, drums
- Pallets
- Sacks

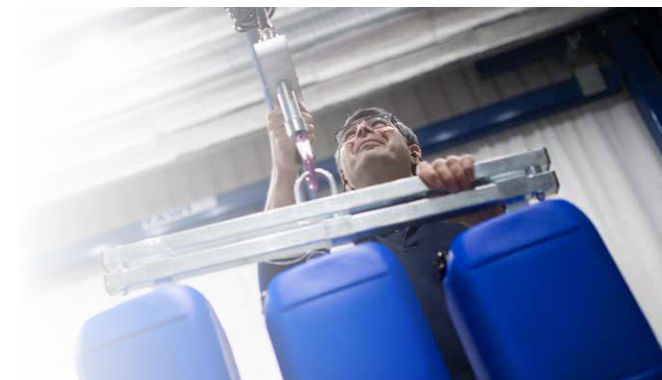

Speedy and efficient

- Up to 0.75 m/s lifting speed
- Variable speed control
- User-friendly joystick handle makes the hoist easy and efficient to work with
- Quick coupling allows quick change of tools
- Lifting capacity 60/120 kg (wire hoist)



Cost-efficient and sustainable

- low energy consumption
- low cost of ownership
- easy to install and requires little maintenance



Heavy duty chain hoist

- Lifting capacity <2 500 kg
- IP65, suitable for outdoor use
- Chain safety factor min 8 times (FEM, 2m, ISO, M5)
- Low-wear DC-spring-loaded brake



型号与技术参数

	TAWI 灵动提 Vh60/VH120	TAWI 泰然提
升降能力	60/120 kg	<1 600 kg
升降速度	0.75/0.35 m/s	8/2 m/min
电源	230V +/-10%	3x400V
升降高度	2 000 mm	4 000 mm
速度控制	variable	2-speed
频率	47-63 Hz	50 Hz

TAWI提供全系列的钢丝绳电动葫芦和链式电动葫芦。当你需要高速、精准搬运时，TAWI灵动提电动葫芦是您最佳的选择。TAWI泰然提电动葫芦动力强劲、耐用，是大负载和恶劣条件下搬运的正确选择。

这两种电动葫芦都提供了一系列的工具来处理各种类型的货物，从各种袋装货物、桶装货物到汽车底盘甚至整面墙。



TAWI真空夹具

	水平	垂直
能力	500 kg	250 kg
真空源	电动或气动	电动或气动
吸盘	两倍负载尺寸	四倍负载尺寸
倾斜	-	90°

TAWI真空抓取轭安装在链式电动葫芦上，可方便、高效地处理各种类型的钣金。采用电动或气动真空源，抓取轭可以抓住大块的玻璃板、金属板、木板和塑料板。垂直型可以90度倾斜，而水平型可以处理重达500公斤的沉重负载。

真空轭有两种标准型号，也可根据您的特殊要求个性化定制。如有需求，请联系我们，为您选择最合适的工具。

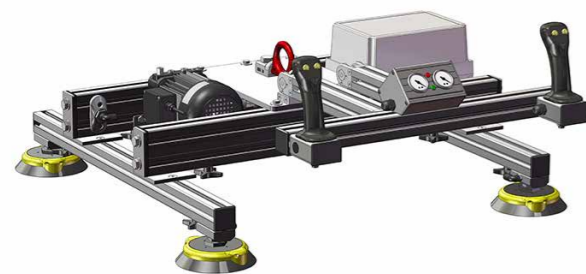

Models and technical details

	ViperHoist Vh60/VH120	Chain Hoist
Lifting capacity	60/120 kg	<1 600 kg
Lifting speed	0.75/0.35 m/s	8/2 m/min
Power supply	230V +/-10%	3x400V
Lifting height	2 000 mm	4 000 mm
Speed control	variable	2-speed
Frequency	47-63 Hz	50 Hz

TAWI offers a complete selection of wire hoists and chain hoists. The wire hoist is the preferable choice when you need to lift with speed and precision. The chain hoist is very powerful and durable, the right choice for heavier loads and for lifting in tough conditions.

Both hoists offer a selection of tools for handling all types of loads, anything from sacks or drums to car chassis or entire walls.



TAWI Grip vacuum yoke

	Horizontal	Vertical
Lifting capacity	500 kg	250 kg
Vacuum source	electric or pneumatic	electric or pneumatic
Suction cups	dimensioned for double the load	dimensioned for four times the load
Tilt	-	90°

Mounted in a chain hoist TAWI Grip vacuum yoke allows easy and efficient handling of all types of sheet materials. Using an electric or pneumatic vacuum source, the yoke safely holds big sheets of glass, metal, wood or plastic. The vertical model allows 90° tilt, while the horizontal model can handle heavier loads, up to 500 kg.

The vacuum yoke is available in two standard models but can also be customized to meet specific customer requests. Talk to your local TAWI representative and they will help you find the best tool for your needs.

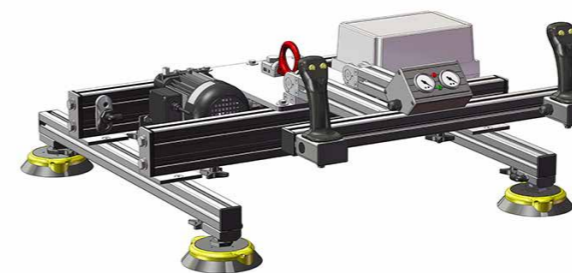

TAWI真空夹具

处理各种类型的板材

- 玻璃板
- 金属板
- 层压板
- 塑料板
- 木板

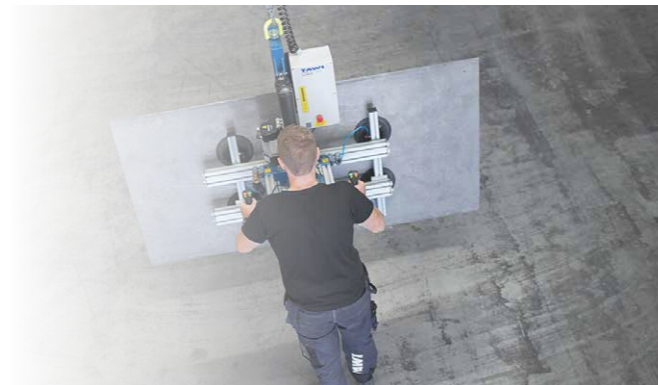

倾斜与翻转

- 轻易倾斜和翻转大块板材
- 倾斜度可达180度
- 采用数控技术

符合人体工程学的人性化设计

- 人性化的控制面板
- 紧凑设计, 适应您的需求
- 符合人体工程学的设计最大限度地减少了拉伤或受伤风险



需求化定制

- 该工具可定制, 以满足您的各种需要
- 可定制适合您的负载吸盘
- 倾斜和旋转功能可适应您的工作流程和需求

TAWI Grip

Handling all types of sheets

- Glass
- Metal
- Laminate
- Plastic
- Wood

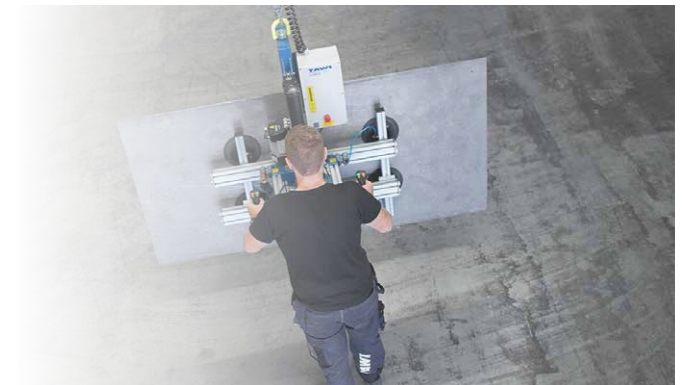

Tilt and turn

- Tilt and turn big sheets effortless and easy
- Up to 180° tilt
- CNC loading

Ergonomic and user-friendly

- User-friendly control panel
- Compact design
- Adaptable to your needs
- Ergonomic design minimises the risk of straining or injury

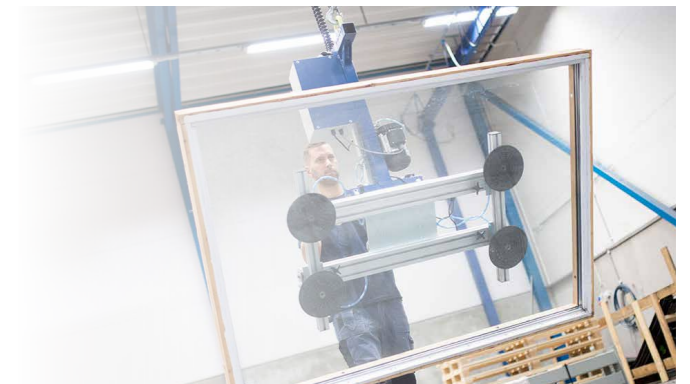

Custom made

- The tool can be custom made to meet your every need
- Suction cups adapted to your load
- Tilt and turn functionality adaptable to suit your workflow and requirements

高效搬运的可靠基石

我们的起重机设备为您度身定制融入于您的生产流程，确保您高效搬运，顺利生产。^{TAWI} 随行架和^{TAWI} 变形臂随心所欲搬运您的货物。

我们可提供灵活的安装方案满足您的使用需求。可在天花板或房梁上安装钢铝结构，适应您的设施，满足您的需求，同时可为您的各类厂房完美适配顶部桥式起重机。

通过多款标准悬臂起重机，结合我们的改造能力，我们总能根据您的需求找到理想的解决方案。

^{TAWI} 起重机系统非常可靠，它可持续运行数十年。所有的材料由优质钢材制成，并覆盖表面涂层，所有部件均无缝焊接。选择^{TAWI}，岁月静好。

A reliable foundation for efficient lifting

A crane system built for your needs, integrated in your workflow, will help ensure efficient lifting and productive processes. ^{TAWI} Overhead Bridge Cranes and ^{TAWI} Jib Cranes give you the freedom to lift and move goods exactly where you need them.

^{TAWI} crane systems offer flexible solutions for mounting lifters so that you can use them wherever you need. Steel or aluminium profiles can be mounted in the ceiling or on floor pillars, built to match your facilities and meet your every need. No matter how your facilities are constructed, we will build an overhead crane system that is ideal for your conditions.

With a selection of standard jib cranes, and the ability to modify cranes to customer requests, we can always find an ideal solution for your business needs.

^{TAWI} cranes are reliable systems that will help keep your operations running for decades. The profiles are produced from high-quality steel, finished off with a protective coating. Parts are merged together seamlessly, making sure whatever you suspend in the system will run smoothly for many years to come.

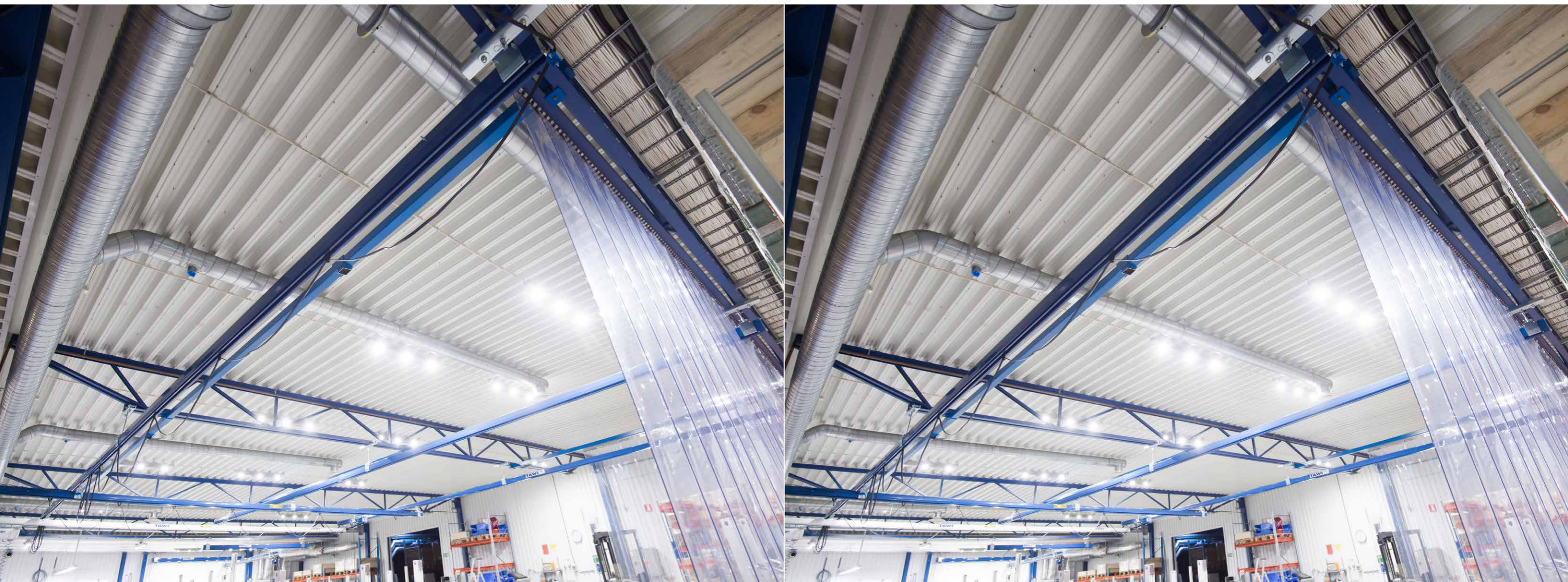

TAWI起重机设备

多种选择

- 铝制或钢型材
- 安装在天花板或楼柱上
- 直接悬挂在天花板或房梁上
- 通过手动或遥控移动搬运
- 便携式悬臂起重机具有更大的灵活性
- 根据您的设施调整负载能力



需求化定制

- TAWI起重机设备始终按客户的要求定制
- 适合您的设施和要求
- 轻松地与您的作业流程相协调
- 可选择TAWI标准蓝色涂层, 或自定义颜色

成套系统

- 单梁或双梁起重机
- 为低净空间而建的低构架系统
- 不锈钢设备便于清洁
- 悬臂式起重机可壁挂安装或安装在立柱上
- 可提供便携式方案



强大的悬架

- 高达1500kg搬运能力
- 悬挂点之间距离高达8000mm
- 可触及范围大



TAWI crane systems

Many options

- Aluminium or steel profiles
- Mounted in ceiling or on floor pillars
- Suspended directly in ceiling or in roof beams
- Move lifters by manual power or remote control
- Portable jib cranes for greater flexibility
- Overbraced or underbraced depending on what suits your facilities



Customization

- TAWI crane systems are always built on customer request
- Adapted to your facilities and requirements
- Easily integrated in your workflow
- Delivered in TAWI blue coating, or the colour of your choice

Complete range of systems

- Single and double girder cranes
- Low built system for low headroom areas
- Stainless steel systems for easy cleaning
- Jib cranes mounted on wall or pillar
- Portable options available



Powerful suspension

- Up to 1 500 kg lifting capacity
- Up to 8 000 mm between suspension points
- Provides great range of motion when lifting with vacuum lifters or hoists

